

ROLL FORMING MACHINE

Main Driver:
VFA7

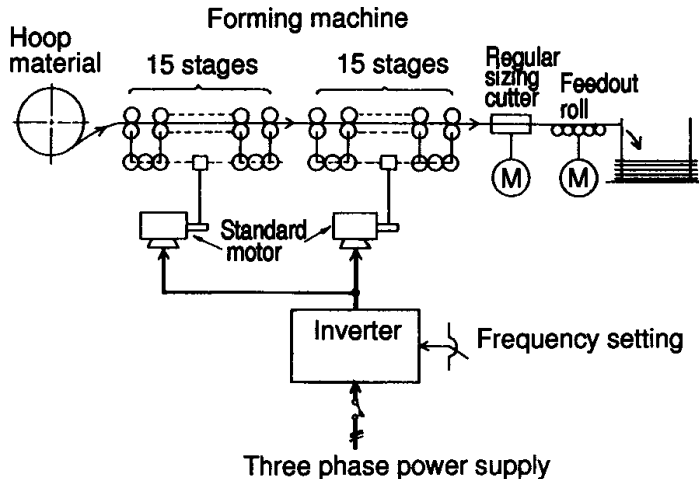

This machine produces formed articles like sash bars from a hoop. An inverter drives two motors simultaneously, and depending on the thickness, the formed shape and size of the hoop sheet, the line speed can be set optionally.

Advantages of adopting an inverter

1. **Optimization of line speed**
A 4 step change has been conventionally used. Introduction of an inverter enables optional setting of speed.
2. **Cushioned start/ stop** is possible enabling improvement of operational behavior.
3. Applicable to existing systems.
4. On setting like replacement of hoop, simple pushing of a button switch enables cushioned start/ stop operation of the machine.