

CONVEYOR

Main Driver:
VFA7

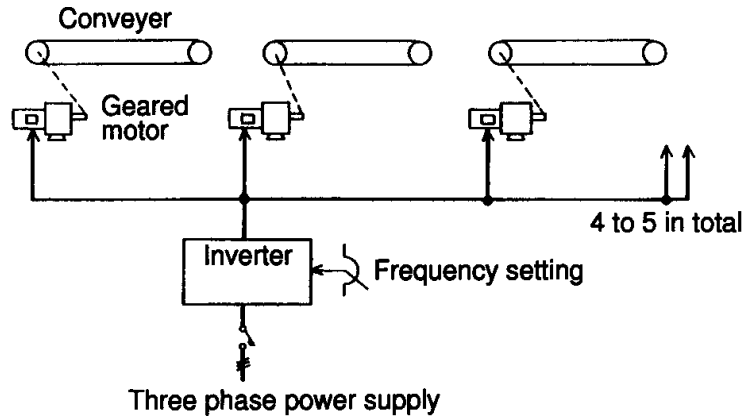

An example of inverter driving of conveyors on a production line. Conveyor speed can be adjusted according to the type of the product enhancing productivity.

Advantages of adopting an inverter

1. **Improvement of productivity**
Productivity will be improved by adoption of conveyor line speed control using an inverter.
2. Since one inverter drives several motor collectively, a **constant line speed** setting becomes possible.
3. Application to existing systems
Enables application on as is existing systems.