

# SHOWCASE FREEZER

Main Driver:  
VFA7

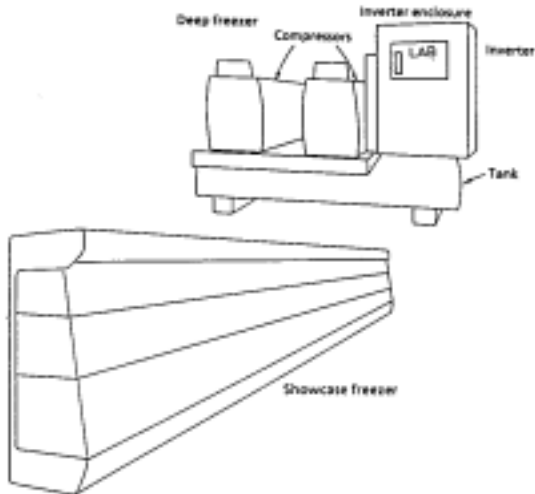

This is an example of applying an inverter to a showcase freezer system used at supermarkets and department stores.

## Advantage of adopting an inverter

1. Precise temperature control  
The variable speed control of compressor motors allows constant and optimum temperature regulation required for foodstuff preservation with minimum temperature fluctuation.
2. Energy savings  
The use of an inverter permits a rapid freezing within a designated period contributing to energy savings and reduces costs.
3. Easy operation  
Temperature setting for freezing and refrigeration, depending on foodstuff types, can be selected simply by pressing buttons.

## Notes on application

1. The operating frequency range of the compressor must be set in advance. Particularly, continuous operation at low frequency requires utmost care.
2. When a reciprocating type compressor is used, selection of inverter capacity requires careful consideration.
3. In the event of a power interruption and subsequent recovery, a certain period is required until the operation can be restarted.