

# Totally enclosed box type

Possible to bring into compliance with IP55 specifications!

- Operation panel
- Frequency setting potentiometer
- Operation switch
- Slots for additional switches (Two)
- Power switch for motor circuit breaker



<UL compliant type>



## Line-up

Input voltage class	Applicable motor (kW)					
	0.2	0.4	0.75	1.5	2.2	4.0
1-phase 240V	IP54					
3-phase 240V	IP54					
3-phase 500V	IP54					

- Totally enclosed structure compliant with IP54
- Built-in noise filter
- Equipped with all control devices as standard (Control devices compliant with IP55 specifications / All-in-one)
- Built-in motor circuit breaker
- Minimum wiring
- Cooling structure: Self-cooling type

## External dimensions

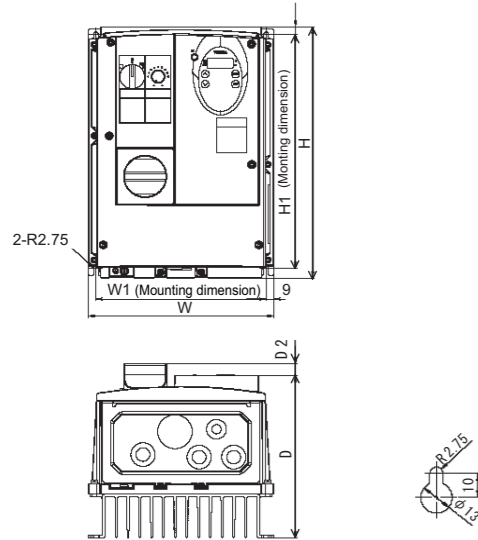

## External dimensions

Input voltage class	Applicable motor (kW)	Inverter type	Dimensions (mm)						Cabling hole	Approx. weight (kg)
			W	H	D	W1	H1	D2		
3ph-240V	0.4	VFS11-2004PME	210	240	163.3	192	218	13.7	φ 19x3 φ 21x1	3.9
	0.75	VFS11-2007PME	210	240	163.3	192	218	13.7	φ 19x3 φ 21x1	3.9
	1.5	VFS11-2015PME	215	297	192.3	197	277	13.7	φ 19x1 φ 23x3	5.9
	2.2	VFS11-2022PME	215	297	192.3	197	277	13.7	φ 19x1 φ 23x3	5.9
3ph-500V	4.0	VFS11-2037PME	230	340	208.3	212	320	13.7	φ 19x1 φ 23x3	7.6
	0.75	VFS11-4007PLE	215	297	192.3	197	277	13.7	φ 19x1 φ 23x3	6.1
	1.5	VFS11-4015PLE	215	297	192.3	197	277	13.7	φ 19x1 φ 23x3	6.1
1ph-240V	2.2	VFS11-4022PLE	230	340	208.3	212	320	13.7	φ 19x1 φ 23x3	8.0
	4.0	VFS11-4037PLE	230	340	208.3	212	320	13.7	φ 19x1 φ 23x3	8.0
	0.2	VFS11S-2002PLE	210	240	163.3	192	218	13.7	φ 19x3 φ 21x1	4.0
	0.4	VFS11S-2004PLE	210	240	163.3	192	218	13.7	φ 19x3 φ 21x1	4.0
1ph-240V	0.75	VFS11S-2007PLE	215	297	192.3	197	277	13.7	φ 19x1 φ 23x3	6.0
	1.5	VFS11S-2015PLE	215	297	192.3	197	277	13.7	φ 19x1 φ 23x3	6.0
	2.2	VFS11S-2022PLE	230	340	208.3	212	320	13.7	φ 19x1 φ 23x3	7.6

## Standard specifications

\* Other specifications are the same as those of the standard type. See common specification on page 6.

Item		Specification						
Input voltage class		1ph-240V input class / 3ph-240V input class / 3ph-500V input class						
Applicable motor (kW)		0.2	0.4	0.75	1.5	2.2	4.0	
Model	Input voltage class	Type						
	1ph-240V class	VFS11S-						
	3ph-240V class	VFS11-						
	3ph-500V class	VFS11-						
Rating	Capacity(kVA) Note 1	0.6	1.3	1.8	3.0/3.0/3.1	4.2	6.7/7.2	
	Rated output current (A) Note 2	1ph-240V class	1.5 (1.5)	3.3 (3.3)	4.8 (4.4)	8.0 (7.9)	11.0 (10.0)	-
		3ph-240V class	-	3.3 (3.3)	4.8 (4.4)	8.0 (7.9)	11.0 (10.0)	17.5 (16.4)
		3ph-500V class	-	-	2.3 (2.1)	4.1 (3.7)	5.5 (5.0)	9.5 (8.6)
Output voltage Note 3	240V class : 3ph-200V to 240V, 500V class : 3ph-380V to 500V							
Overload current rating	150% -60 seconds, 200% -0.5 second							
Power supply	Voltage-frequency	240V class : 1ph/3ph-200V to 240V -50/60Hz, 500V class : 3ph-380V to 500V -50/60Hz						
	Allowable fluctuation	Voltage +10%, -15% Note4), frequency ±5%						
Protective method		IP54 Totally enclosed type (JEM1030) / Possible to bring into compliance with IP55						
Cooling method		Self-cooling						
Color		Munsel 5Y-8/0.5						
Built-in filter		1ph and 500V class : High-attenuation EMI filter, 3ph-240V class : Basic filter						
Environment	Service environments Note 6)	Indoor, altitude 1000m or less. Place not exposed to direct sunlight and free from of corrosive and explosive gases.						
	Ambient temperature	-10 to +40°C						
	Storage temperature	-25 to +70°C						
	Relative humidity	20 to 93%						
	Vibration	5.9 m/s <sup>2</sup> or less (10 to 55Hz)						

Note 1: Capacity is calculated at 220V for the 240V class and at 440V for the 500V class.  
 Note 2: Indicates rated output current setting when the PWM carrier frequency (Parameter F300) is 4kHz or less. When exceeding 4kHz, the rated output current setting is indicated in the parenthesis.  
 Note 3: The maximum output voltage is equal to the input supply voltage.  
 Note 4: ±10% when the inverter is operated continuously (under a load of 100%).  
 Note 5: The factory default settings of the following parameters are different from those of the standard type. The factory default settings of all other parameters are the same as those of the standard type. For parameter settings, see the tables of parameters on page 10. periodically.

Title	Function	VF-S11 Standard type	VF-S11 totally enclosed type
CMD	Command mode selection	1	0
FMD	Frequency setting mode selection	0	2

Note 6: Installation environment  
 • Install the inverter in a well-ventilated place and mount it on a flat metal plate in portrait orientation. Install the inverter so that it is not inclined more than ±10° from the vertical.  
 • Leave a space of 10 cm or more on the upper and lower sides of the inverter, and a space of 5 cm or more on each side.  
 • The inverter has a cooling fan to circulate air in it. The cooling fan has a useful life of approximately 30,000 hours (2 to 3 years when operated continuously), so it needs to be replaced periodically.

## Compliance with IP55

IP54-compliant structures refer to structures that protect the contents from dust and harmful effects of water that drops from every direction. The inverter can be brought into compliance with IP55 specifications by making the wiring port watertight. (IP55-compliant structures refer to structures that protect the contents from dust and harmful effects of water that comes in a jet from every direction.)

## Standard connection diagram

### Sink (Negative) logic : Common = CC

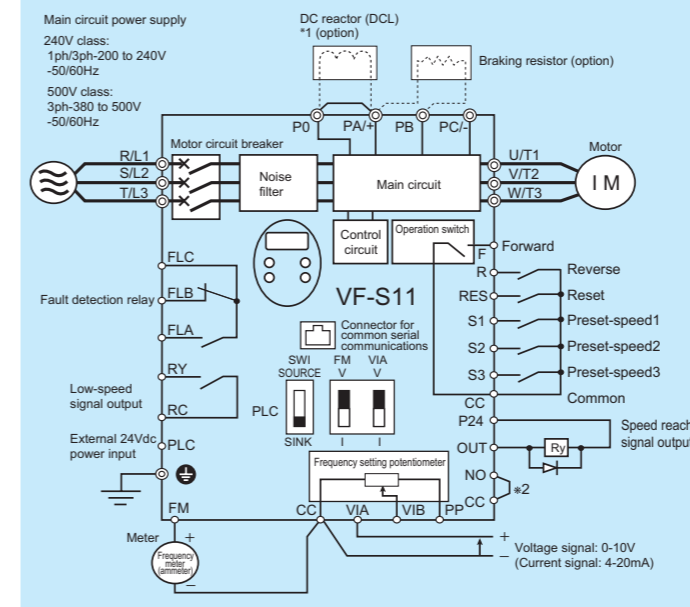

### Source (Positive) logic : Common = P24

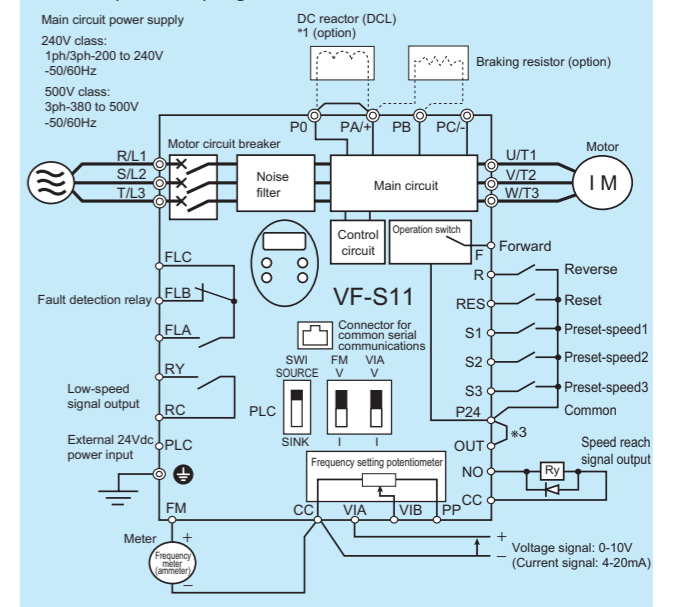

\*1: The inverter comes with the PO and PA (positive) terminals short-circuited with a shorting bar. When connecting a DC reactor (DCL), detach the shorting bar.  
 \*2: When using the OUT output terminal in a sink logic configuration, do not short-circuit the NO and CC terminals.  
 \*3: When using the OUT output terminal in a sink logic configuration, do not short-circuit the P24 and OUT terminals.

Totally enclosed box type

Totally enclosed box type