

# Standard connection diagrams

## Standard connection diagram : Sink logic (common : CC)

Main circuit power supply

- 200V class: 0.4~75kW 3-phase, 200 to 240V-50/60Hz
- 400V class: 0.75 to 90kW 3-phase, 380 to 240V-50/60Hz
- 110 to 500kW 3-phase, 380 to 440V-50Hz
- 3-phase, 380 to 480V-60Hz

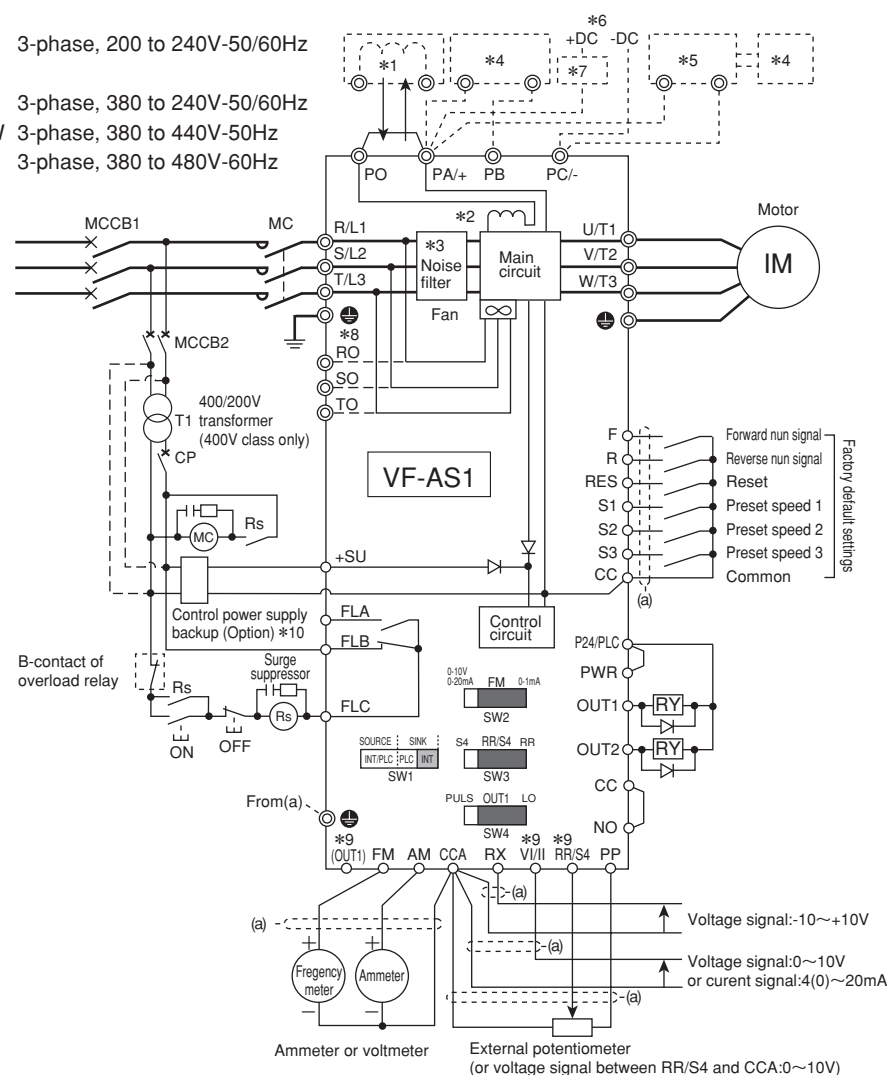

- \*1 : The inverter is shipped with the terminals PO and PA/+ shorted with a bar (200V-45kW or smaller, 400V-75kW or smaller). Remove this shorting bar when installing a DC reactor (DCL). For 200V-55kW or more, and 400V-90kW or more models, be sure to install the DC reactor.
- \*2 : The DC reactor is built in for models 200V-11kW~45kW and 400V-18.5kW~75kW.
- \*3 : The noise filter is built in for models 200V-45kW or smaller and all of 400V.
- \*4 : External braking resistor (option). Dynamic braking drive circuit built-in (GTR7) as standard for models 160kW or smaller.
- \*5 : Power generation braking Unit (option). when the external braking resistor (optional) is used on 200kW or more models, the separate power braking unit (optional) is required.
- \*6 : To supply a DC power, connect the cables to the PA/+ and PA/- terminals.
- \*7 : If want to use DC power supply to operate the inverter (200V: 18.5kW or more, 400V: 22kW or more), be sure to contact your supplier customer support center, because an inrush current limiting circuit is required in such a case.
- \*8 : For models 200V-75kW and 400V-110kW or larger, three-phase power input is necessary to drive the fan if you want to use a DC power supply.
- \*9 : The functions assigned to terminals OUT1, VI/II and RR/S4 can be switched by changing parameter settings.
- \*10 : To supply control power from an external power supply for backing up the control power supplied from the inverter. an optional control power backup device (CPS002Z) is required. In such a case, the backup device is used at the same time with the internal power supply of the inverter. The optional control power backup unit can be used with both 200V and 400V models.
- \*11 : The rating of 400V-355 to 500kW have the double terminals of R/L1, S/L2, T/L3 for power input, and PO for DC reactor. Please refer the following figure for the wiring.

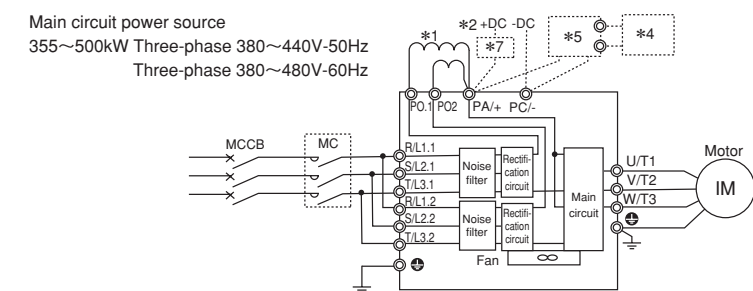

## Standard connection diagram : Source logic (common : P24)

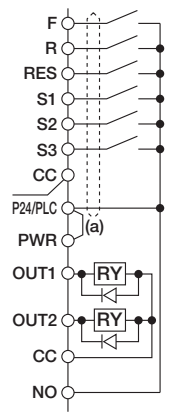
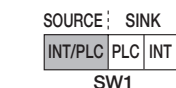

# Terminal functions

## Main circuit terminal

Terminal Symbol	Terminal Function
⊕	Grounding terminal for inverter casing
R/L1, S/L2, T/L3	200V class: 0.4~75kW Three-phase 200~240V-50/60Hz 400V class: 0.75~90kW Three-phase 380~480V-50/60Hz 110~500kW Three-phase 380~440V-50Hz Three-phase 380~480V-60Hz (355 to 500kW have the double terminals)
U/T1, V/T2, W/T3	Connect to a (3-phase induction) motor.
PA/+, PB	Connect a braking resistor. (For the optional dynamic braking unit, connect it between PA/+ and PC/-.) Change the parameters $P_b$ , $P_{b-}$ and $P_{bEP}$ if necessary. 200kW models and smaller are not equipped with terminal PB. If you are using such a model and you wish to use a braking resistor, you will need to purchase a braking unit separately.
PC/-	This is a negative potential terminal in the internal DC main circuit. DC common power can be input across the PA/+ terminals (positive potential).
PO, PA/+	Terminals for connecting a DC reactor (DCL: optional external device). Shorted by a short bar when shipped from the factory (200V: 45kW or smaller, 400V: 75kW or smaller). Before installing DCL, remove the short bar. (355 to 500kW have the double terminals of PO)
RO, SO, TO	200V class: 75kW 400V class: 110kW~500kW Inverter's cooling power input terminals. When using a DC power supply, connect three-phase power cables.

## Control circuit terminal

The terminal function settings can be changed according to the application.

Terminal Symbol	Input/output	Function	Electrical Specifications	
F	Input	Shorting across F-CC causes forward rotation; open causes deceleration stop. (Across ST-CC is short state.)	Voltage free contact input 24Vdc-5mA or less Lan current signal. Choose low current contacts to avoid poor attaching. * Sink/source selectable with SW1 Sink input : Less than DC10V Source input : DC11V or more OFF : DC16V or more OFF : Less than DC5V Note: Even when an external power supply is used (in sink logic mode, i.e., when SINK (PLC) is selected), connect the reference potential-side (0V side) cable from the power supply to the CC terminal.	
R	Input	Shorting across R-CC causes reverse rotation; open causes deceleration stop. (Across ST-CC is short state.)		
RES	Input	Shorting and then opening RES-CC cancels the status held by an inverter protective function. When the inverter is operating normally, shorting and then opening RES-CC produces no effect.		
S1	Input	Shorting across S1-CC causes preset speed operation.		
S2	Input	Shorting across S2-CC causes preset speed operation.		
S3	Input	Shorting across S3-CC causes preset speed operation.		
RR/S4	Input	Multifunction programmable input terminal. SW3: When SW4 is in the S4 position, S4 and CC are shorted and preset speed operation is selected.		
P24/PLC	Output	24Vdc power output (when SW1 is in any position other than PLC) 24V internal output terminal		24Vdc-200mA
	Input	If SW1 is turned to the PLC position, this terminal can be used as a common terminal when an external power supply is used.		—
CC*1	Common to input/output	Digital signal equipotential (0V) terminal for the control circuit and equipotential (0V) terminal for an optional control power supply backup.		—
PP	Output	Analog input setting power output		10Vdc (Permissible load current: 10mA)
PWR*2	Input	If P24/PLC and PWR are short-circuited, the motor is put into a standby state. And if the circuit between them is opened, the motor coasts and stops. These terminals can be used for interlock. This terminal is not a multifunction programmable input terminal. It is a terminal with the power removal safety function that complies with EN954-1 category 3 and IEC/EN61508-1 SIL II.	Regardless of the setting of SW1 ON : DC17V or more OFF: Less than DC2V (OFF: Coast stop)	
RR/S4	Input	SW3: Multifunction programmable analog input terminal when SW4 is in the RR position. Standard default setting: 0~10Vdc input and 0~60Hz frequency.	10Vdc (Internal impedance: 30 kΩ)	
VI/II	Input	Multifunction programmable analog input. Standard default setting: 0~10Vdc input and 0~60Hz frequency. This terminal can also be used as a 4~20mA (0~20mA) input terminal, if the parameter $F_{I2}$ set to 1.	10Vdc (Internal impedance: 30 kΩ) 4~20mA (Internal impedance: 242Ω)	
RX	Input	Multifunction programmable analog input. Standard default setting: 0~±10Vdc input and 0~±60Hz frequency.	10Vdc (Internal impedance: 22 kΩ)	
FM	Output	Multifunction programmable analog output. Standard default setting: output frequency Connect a 1mA full-scale ammeter or 7.5Vdc (10Vdc)-1mA full-scale voltmeter. This terminal can also be used as a 0~20mA (4~20mA) terminal, if the parameter $F_{68}$ set to 1 and the SW2 switch is set to OFF.	1mA full-scale DC ammeter or 7.5Vdc-1mA full-scale DC voltmeter 0~20mA (4~20mA) Full-scale DC ammeter	
AM	Output	Multifunction programmable analog output. Standard default setting: output current Use this terminal to connect a 1mA full-scale ammeter or 7.5Vdc (10Vdc)-1mA full-scale voltmeter.	1mA full-scale DC ammeter or 7.5Vdc-1mA full-scale DC voltmeter	
OUT1	Output	Multifunction programmable open collector output. The default setting is to output a signal when output low speed threshold has been reached. Depending on the SW4 setting, pulses are output with frequencies of 1.00kHz to 43.20kHz. Standard default setting: 3.84kHz	Open collector output 24Vdc-50mA *Sink logic/source logic switchable	
OUT2		Multifunction programmable open collector output. By default, it is set to output a signal indicating the completion of acceleration or deceleration.		
NO		Digital output signal equipotential (0V) terminal for the control circuit. It is insulated from the CC terminal.		
CCA*1	Common to input/output	Analog input/output signal equipotential (0V) terminal for the control circuit.	—	
+SU	Input	DC power input terminal for operating the control circuit. Connect a control power backup device (optional) between +SU and CC.	Voltage: 24Vdc±10% Use a power supply with a current rating of 1.1A or more.	
FLA FLB FLC	Output	Relay contact output. Contact rating Used to detect the activation of the inverter's protective function. Contact across FLA-FLC is closed and FLB-FLC is opened during protection function operation.	250Vac-2A 30Vdc-1A :at resistance load 250Vac-1A :cosF=0.4	

\*1: Although the CC terminal and the CCA terminal are not insulated, they should be used separately, one for the logic circuit and the other for the analog circuit.  
\*2: The PWR terminal is not the same as the ST (standby signal input) terminal provided for conventional models. To use the ST function, assign it to a multifunction terminal (F, R, RES or S1 to S4) that is not currently in use.  
Example: When assigning the ST function to the S3 terminal.  
Set  $F_{I2}$  to 0, and Set  $F_{I1}$  to 5.  
These settings put the motor into a standby state if S3 and CC are short-circuited, or coast and stop the motor if the circuit between S3 and CC is opened.