

# Standard connection diagram

This diagram shows a standard wiring of the main circuit.

■Standard connection diagram-SINK (Negative) (common:CC)

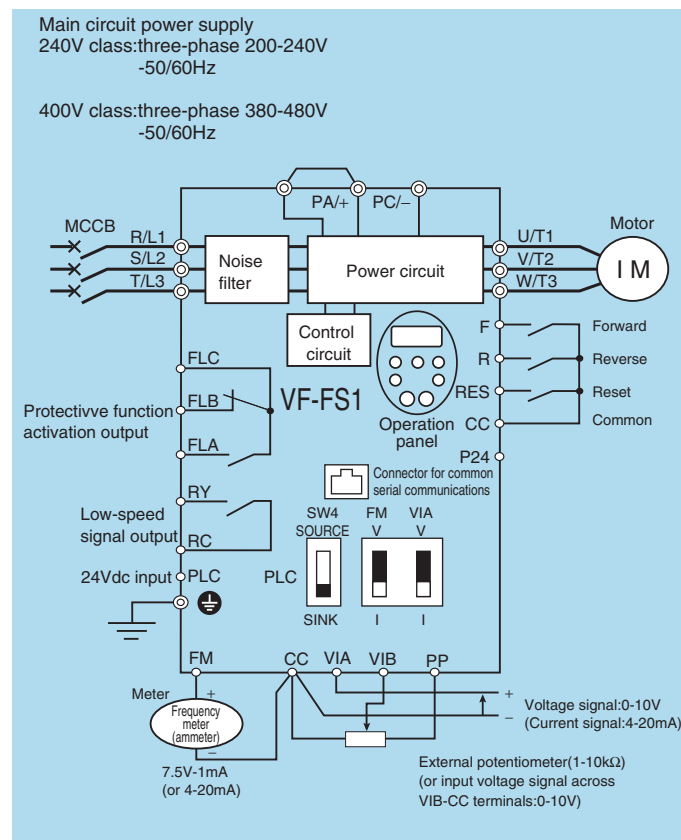

■Standard connection diagram - SOURCE (Positive) (common:P24)

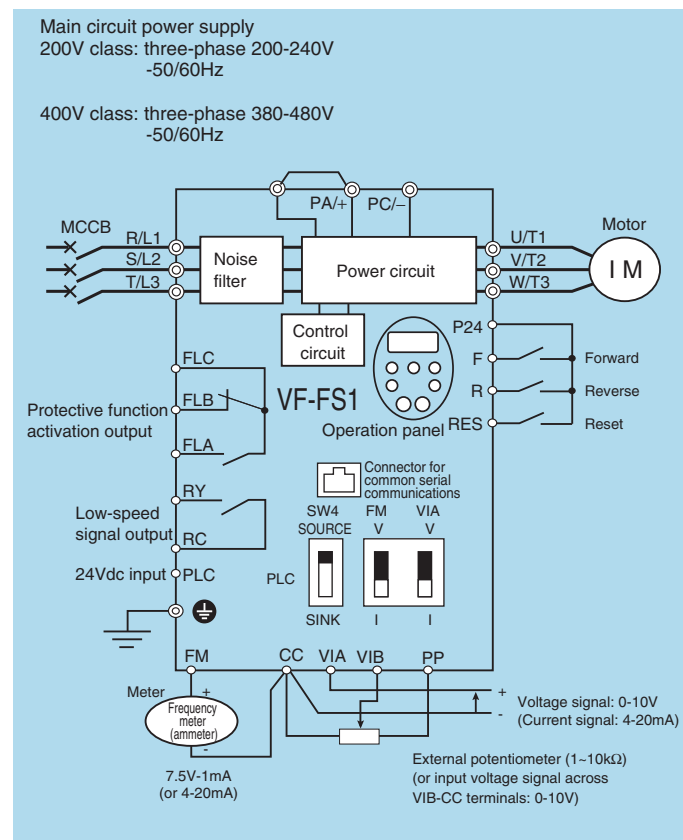

## Main circuit terminal

Terminal symbol	Terminal function
	Grounding terminal for connecting inverter. There are 3 terminals in total. 2 terminals in the terminal board, 1 terminal in the cooling fin.
R/L1, S/L2, T/L3	200V class: three-phase 200 to 240V-50/60Hz 400V class: three-phase 380 to 480V-50/60Hz
U/T1, V/T2, W/T3	Connect to a (three-phase induction) motor.
PA/+, PC/-	PA/+ terminal: Positive potential terminal for the internal DC main circuit PC/- terminal: Negative potential terminal for the internal DC main circuit DC power can be supplied through the PA/+ and PC/- terminals.

## Control circuit terminal

Terminal symbol	Input/output	Function	Electrical specifications
F	Input	Multifunction programmable contact input	No voltage contact input 24Vdc-5mA or less  *Sink/Source/PLC selectable using SW4
R	Input		
RES	Input		
PLC	Input (common)	External 24Vdc power input When the source logic is used, a common terminal is connected.	24VDC (Insulation resistance: DC50V)
CC	Common to Input/output	Control circuit's equipotential terminal (2 terminals)	—
PP	Output	Analog power supply output	10Vdc (permissible load current: 10mA)
VIA	Input	Multifunction programmable analog input. Factory default setting: 0~10Vdc/0~60Hz (0~50Hz) frequency input. The function can be changed to 4~20mAdc (0~20mA) current input by flipping the VIA (SW3) dip switch to the I position.  By changing parameter setting, this terminal can also be used as a multifunction programmable contact input terminal. When using the sink logic, be sure to insert a resistor between P24-VIA (4.7 kΩ/1/2 W). Also move the VIA (SW3) dip switch to the V position.	10Vdc (internal impedance: 30kΩ)  4-20mA (internal impedance: 250Ω)
VIB	Input	Multifunction programmable analog input. Standard default setting: 0~10Vdc/0~60Hz (0~50Hz) frequency input. PTC thermal input	10Vdc (internal impedance: 30kΩ)
FM	Output	Multifunction programmable analog output. Standard default setting: output frequency. The function can be changed to 0-20mAdc (4-20mA) current output by flipping the FM (SW2) slide switch to the I position.	1mA full-scale ammeter or 7.5Vdc (10Vdc) 1mA full-scale voltmeter 0-20mA (4-20mA) DC ammeter  Permissible load resistance: 750Ω or less
P24	Output	24Vdc power output	24Vdc-50mA
FLA FLB FLC	Output	Multifunction programmable relay contact output. Detects the operation of the inverter's protection function. Contact across FLA-FLC is closed and FLB-FLC is opened during protection function operation.	250Vac-1A(cosφ=1): at resistance load 30Vdc-0.5A, 250Vac-0.5A(cosφ=0.4)
RY RC	Output	Multifunction programmable relay contact output. Standard default settings detect and output low-speed signal output frequencies. Multifunction output terminals to which two different functions can be assigned.	250Vac-1A(cosφ=1): at resistance load 30Vdc-0.5A, 250Vac-0.5A(cosφ=0.4)

## Wiring devices

Voltage class	Capacity of applicable motor (kW)	Input current (A)		Wire size (See Note 4) For IEC60364-5-523/54		Molded case circuit breaker (MCCB) Earth leakage circuit breaker (ELCB)	Magnetic contactor (MC)
		200V class:200V 400V class:380V	200V class:240V 400V class:480V	Power circuit (mm <sup>2</sup> ) Note 1)	Earth cable (mm <sup>2</sup> )		
Three-phase 200V class	0.4	1.9	1.6	1.5	2.5	3	25
	0.75	3.3	2.7	1.5	2.5	5	25
	1.5	6.1	5.1	1.5	2.5	10	25
	2.2	8.7	7.3	1.5	2.5	15	25
	3.7	15.7	13.0	2.5	2.5	30	25
	5.5	20.8	17.3	4	4	40	32
	7.5	27.9	23.3	6	6	50	40
	11	42.1	34.4	10	10	75	50
	15	56.1	45.5	16	16	100	80
	18.5	67.3	55.8	25	16	100	80
Three-phase 400V class Note 9)	0.4	1.0	0.8	1.5	2.5	3	25
	0.75	1.7	1.4	1.5	2.5	3	25
	1.5	3.2	2.5	1.5	2.5	5	25
	2.2	4.6	3.6	1.5	2.5	10	25
	3.7	8.1	6.4	1.5	2.5	15	25
	5.5	10.9	8.6	1.5	2.5	20	25
	7.5	14.7	11.7	1.5	2.5	30	32
	11	21.1	16.8	4	4	40	32
	15	28.5	22.8	6	6	50	40
	18.5	34.8	27.8	6	6	60	50
22	41.6	33.1	10	10	75	80	
30	56.7	44.7	16	16	100	80	

Note 1: Sizes of the wires connected to the input terminals R/L1, S/L2 and T/L3 and the output terminals U/T1, V/T2 and W/T3 when the length of each wire does not exceed 30m.  
Note 2: For the control circuit, use shielded wires 0.75 mm<sup>2</sup> or more in diameter.  
Note 3: For grounding, use a cable with a size equal to or larger than the above.  
Note 4: The wire sizes specified in the above table apply to HIV wires (copper wires shielded with an insulator with a maximum allowable temperature of 75°C) used at an ambient temperature of 40°C or less.  
Note 5: If there is a need to comply with UL standard, use correct size of UL wires.

Note 6: Selections for use of the Toshiba 4-pole standard motor with power supply voltage of 200V/400V-50Hz.  
Note 7: Choose the MCCB according to the power supply capacity.  
For comply with UL and CSA standard, use the fuse certified by UL and CSA.  
Note 8: When using on the motor side during commercial-power supply operation, choose the MC with class AC-3 rated current for the motor rated current.  
Note 9: Attach surge killers to the magnetic contactor and exciting coil of the relay.  
Note 10: In the case the magnetic contactor (MC) with 2a-type auxiliary contacts is used for the control circuit, raise the reliability of the contact by using 2a-type contacts in parallel connection.